



# 'K8OS' Radio Science

## **A Vertical Full-Wave Loaded-Loop for 80-Meters**

-

Low-Band DX-Capability in a Reduced Footprint

-

J.B. Anderson, PhD – K8OS  
*k8os@jbglenanderson.com*

# [ Preliminaries.. ]

- A bit of 'k8os' history
  - 'WN8OST' ('65), 'WA8OST' ('66), 'K8OS' ('75)
  - WAS/WAC/DXCC
  - Current interest in HF/DX/Digital modes
  - Member ARRL/AMSAT
- Academics
  - Mathematics (PhD '91), Electrical Engineering (MS '88)
  - Specialization in artificial intelligence, mathematical systems theory, numerical methods, semiconductor noise physics
  - Member PiMuEpsilon/EtaKappaNu
- Professional
  - Technical focus: ultra-low-noise analog design, chip-scale supercomputing, programmable logic, superresolution image processing
  - Worked as hardware architect for a series of Silicon Valley start-ups
  - Currently CTO/Dimension Incorporated (video/image processing R&D)
  - Member IEEE/ACM

# Presentation Content..

- We revisit the classic ‘Vertical Full-Wave-Loop’ (vFWL) antenna
  - vFWL performance attributes
  - How does it work?
  - What happens when we apply loading (i.e., ‘vFWLL’)?
  
- Take-Aways:
  - vFWLL operating principle
    - Why vFWLL is of particular interest
  - Symmetric 4-point loaded 80m/vFWLL design
    - 40m/vFWL Footprint (i.e., ‘quarter-sized’)
  - Performance Modeling with MMANA
    - Reference 80m/vEFHW
  - Physical Design/Build/Deploy/Performance Testing
  - vFWLL as Phased-Array Building-Block

# My Motivation?

- Cheap Gain!
  - 80m DXCC/5B-DXCC (now complete)
  - K0PX/K8OS 80m 'competition' (K0PX Wins!)
- Objective-1: Improved DX performance relative to typical inverted-L, EFHW, horizontal loops, dipoles, etc.
  - ~NVIS: No cloud-heater antennas!
- Objective-2: High-performance option suited to deployment on a city/suburban lot
  - What does the term 'hi-performance' imply for a wire antenna on 80m?
  - Select some known unloaded antenna as reference and explore alternatives
    - e.g., Vertical Dipole/EFHW
- Possibility: Loops have been successful!
  - 8/10 K8OS DXCCs with vFWL
  - Full-sized 80m/vFWL ( $\approx$  65ft/side) isn't feasible. So, what happens if I load the antenna?

# Motivation II..

- Back-Story: (i) Stuck at 94/100 for 80m DXCC (i.e., using EFHW) (ii) K0PX CRUSHES me w/1500W at the (EFHW) antenna! What to do?!
  - Came very close to purchasing a linear, but on reflection decided to continue with 50W (-15dB relative to 1500W)
  - Seeking an alternative approach, I first looked at an MMANA model for my EFHW far-field pattern (result: Classic NVIS 'ball'):

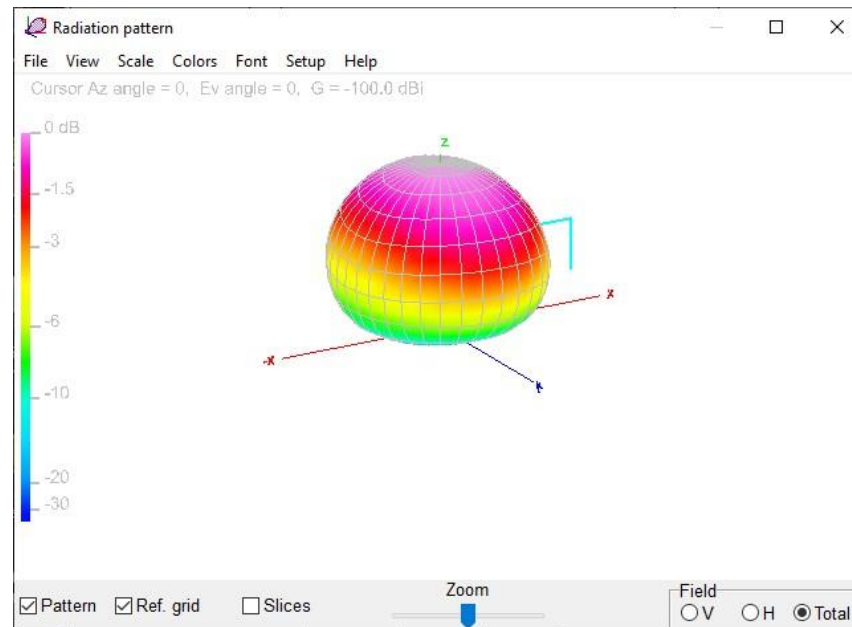

# Why vFWL?

- Recall the FWL operating principle: Far-Field response of two quarter-wavelength sections in superposition (vector sum)
  - Many variations-on-a-theme: Circular, Rectangular, Square
  - Assume 'square': Approx.  $200\Omega$  impedance
  - V/H Polarization depends upon (bottom/side) feedpoint
- FWL antennas are conceptually elegant
  - PRO: Gain antenna, simple/compact physical structure, low-angle radiation (vertical), relative ground-independence, inherently multiresonant on integral multiples of base frequency
  - CON: Requires Balun, multiple support lines, more complex deployment
- Despite advantages, FWL antennas are found mostly 40m and above
  - Compact structure becomes relatively 'large' below 40m
  - Height (available supporting structures), ground-proximity and deviation from 'square' implementation impacts gain and polarization-mix

# [ vFWL Basics (Alternative Shapes).. ]

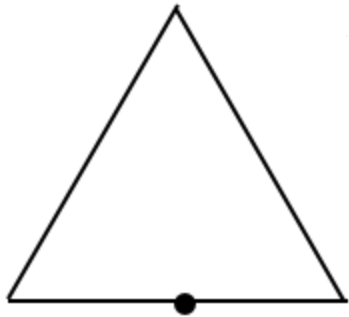

Triangle or Delta

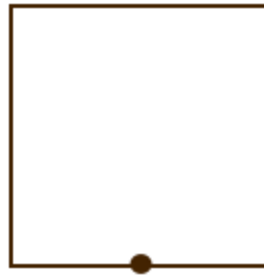

Square or Diamond



Hexagon

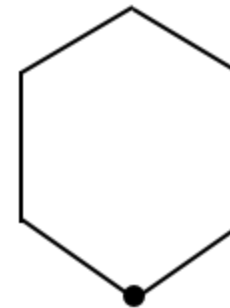
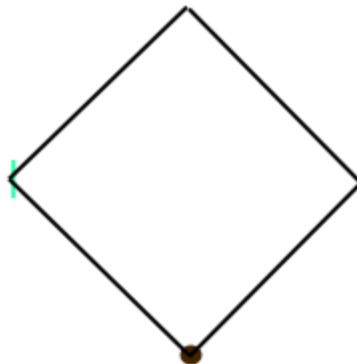
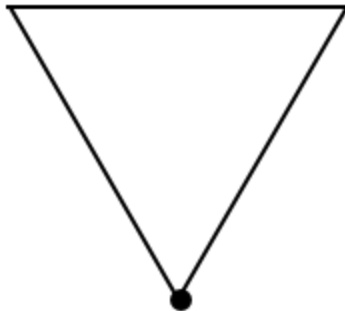

# [ vFWL Basics (Alternate Feedpoints).. ]

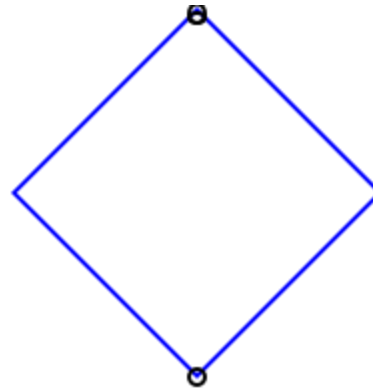
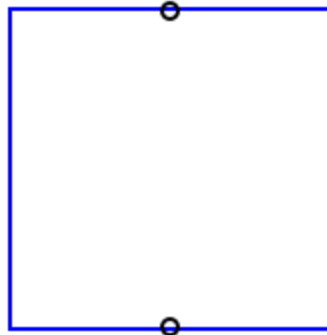

Feedpoints for Horizontal Polarization

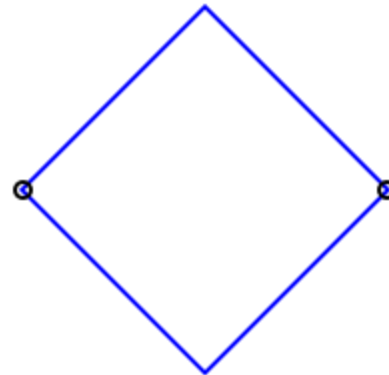
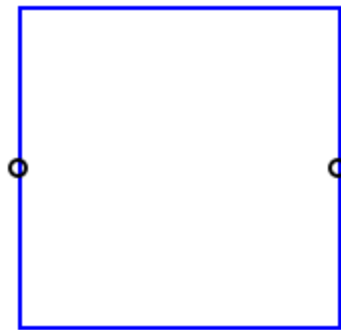

Feedpoints for Vertical Polarization

# vFWL Basics (Current-Distribution)..

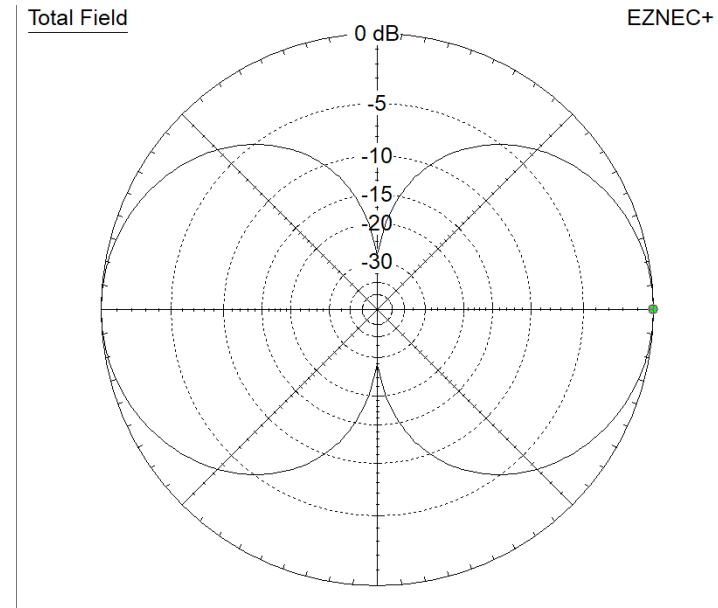
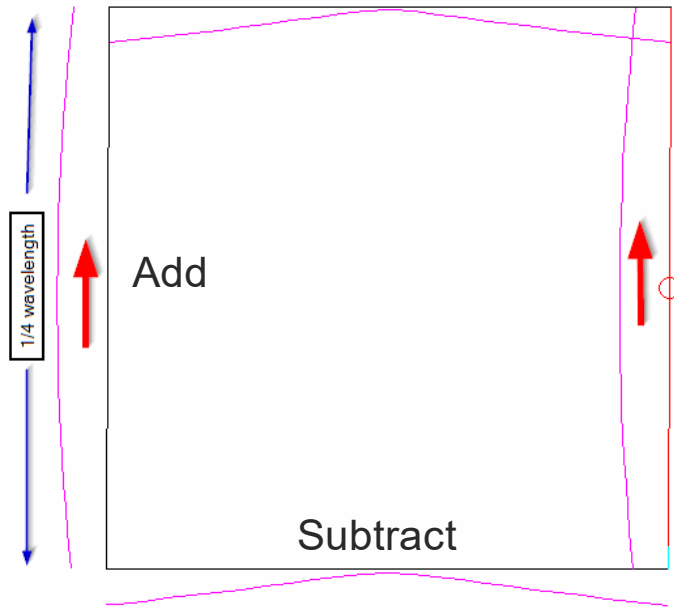

# Antenna 'Loading'.. What does it mean?

- Recall an inductance (or capacitance) introduces complex-valued reactance
  - Frequency/Position-dependent voltage-drop/phase-shift on antenna current path
  - Reactance cancels at resonance (a la antenna 'tune-to-resonance')
- Loading PROs
  - Obtain ' $Z_0$ ' match + useful far-field pattern + reduced footprint
- CONS
  - Reduced aperture + parasitic resistance → Reduced efficiency
- Hope: PROs outweigh CONS!!
  - Design Trade-Off: 'Size' versus 'Performance' (details in sequel)
- Approach: Add symmetrically placed inductors to create anti-symmetric standing-waves on antenna
  - Recall unloaded waveform is also anti-symmetric
  - Obtain classic FWL far-field phase cancellations when folded around loop perimeter

# vFWLL Design Methodology

- Choose footprint 'size' ('square' geometry)
  - 40m vFWL geometry
- MMANA model-based exploration
  - X/Z-plane wire-model at assumed dimensions
  - Add inductors at ' $n\pi/8$ | $n=1,3,5,7$ ' mesh points
  - Perform resonance sweep on inductance value – Identify required 'L'
  - Simulate antenna performance (compare with baseline reference)
- Assumptions:
  - 3.573 MHz design frequency
  - 'Real' ground admittance (re: BP survey data)
  - 1-meter height at lowest point ( $\approx 11$ m total height)

# vFWLL Schematic..

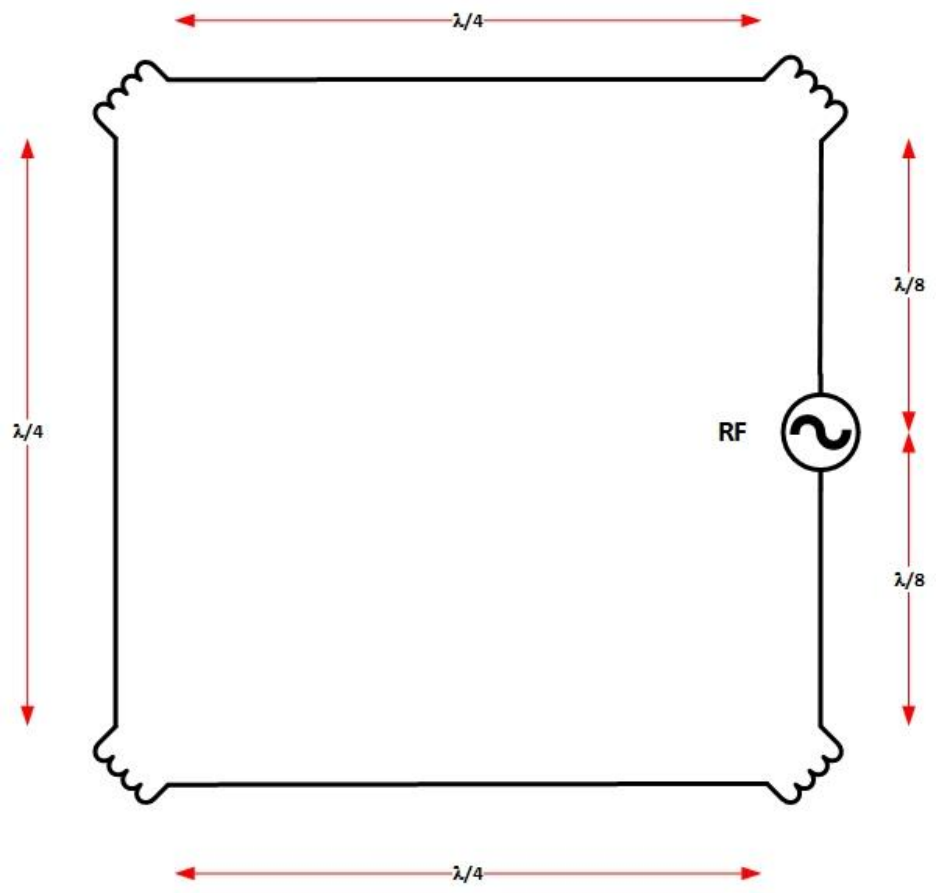

# vFWLL MMANA Setup..

MMANA-GAL basic C:\MMANA-projects\vFWLwLoading-80m\vFWLwLoading-80m.maa

File Edit Tools Setup Help MMANA-GALpro

Geometry View Calculate Far field plots

Name  Freq 3.573 MHz  lambda

Wires 4 Auto segmentation: DM1 800 DM2 80 SC 2.0 EC 2  Keep connect.

| No.  | X1(m) | Y1(m) | Z1(m) | X2(m) | Y2(m) | Z2(m) | R(mm) | Seg. |
|------|-------|-------|-------|-------|-------|-------|-------|------|
| 1    | 0.0   | 0.0   | 0.0   | 0.0   | 9.15  | 0.0   | 0.65  | -1   |
| 2    | 0.0   | 9.15  | 0.0   | 0.0   | 9.15  | 9.15  | 0.65  | -1   |
| 3    | 0.0   | 9.15  | 9.15  | 0.0   | 0.0   | 9.15  | 0.65  | -1   |
| 4    | 0.0   | 0.0   | 9.15  | 0.0   | 0.0   | 0.0   | 0.65  | -1   |
| next |       |       |       |       |       |       |       |      |

Sources 1

| No.  | PULSE | Volt. V | Phase dg |
|------|-------|---------|----------|
| 1    | w2c   | 1.0     | 0.0      |
| next |       |         |          |

Loads 4 (L - uH; C - pF; R/jX - Ohm)  Use loads

| No.  | PULSE | Type | L/R/A0 | C/jX/B0 | Q/A1 | F/B1 |
|------|-------|------|--------|---------|------|------|
| 1    | w1b   | LC   | 54.25  | 0       | 0.0  |      |
| 2    | w2b   | LC   | 54.25  | 0       | 0.0  |      |
| 3    | w4b   | LC   | 54.25  | 0       | 0.0  |      |
| 4    | w3b   | LC   | 54.25  | 0       | 0.0  |      |
| next |       |      |        |         |      |      |

# vFWLL MMANA Current Distribution..

○ Source  
× Load

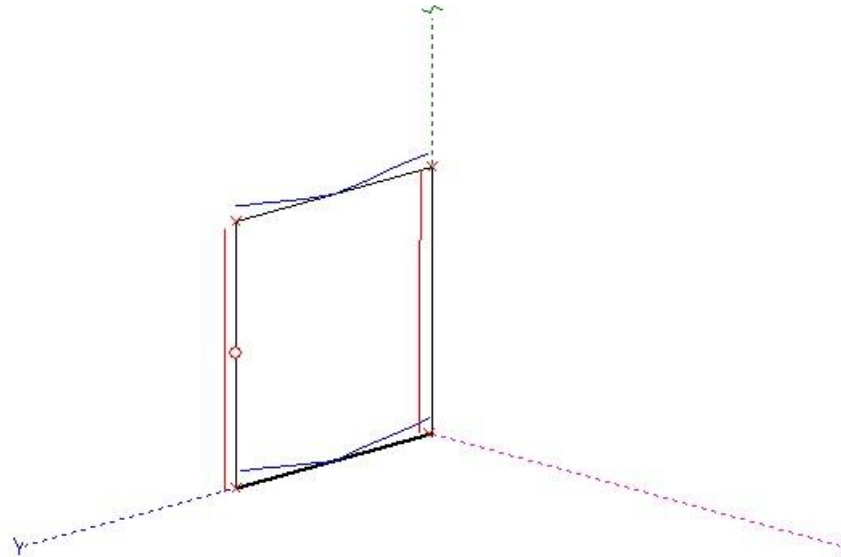

Wire No.1  
X1 : 0.0 m  
Y1 : 0.0 m  
Z1 : 0.0 m  
X2 : 0.0 m  
Y2 : 9.15 m  
Z2 : 0.0 m  
R : 0.65 mm  
Length : 9.15 m  
Azim. : 90.0 deg  
Zenith : 0.0 deg

# [ vFWLL at Resonance.. ]

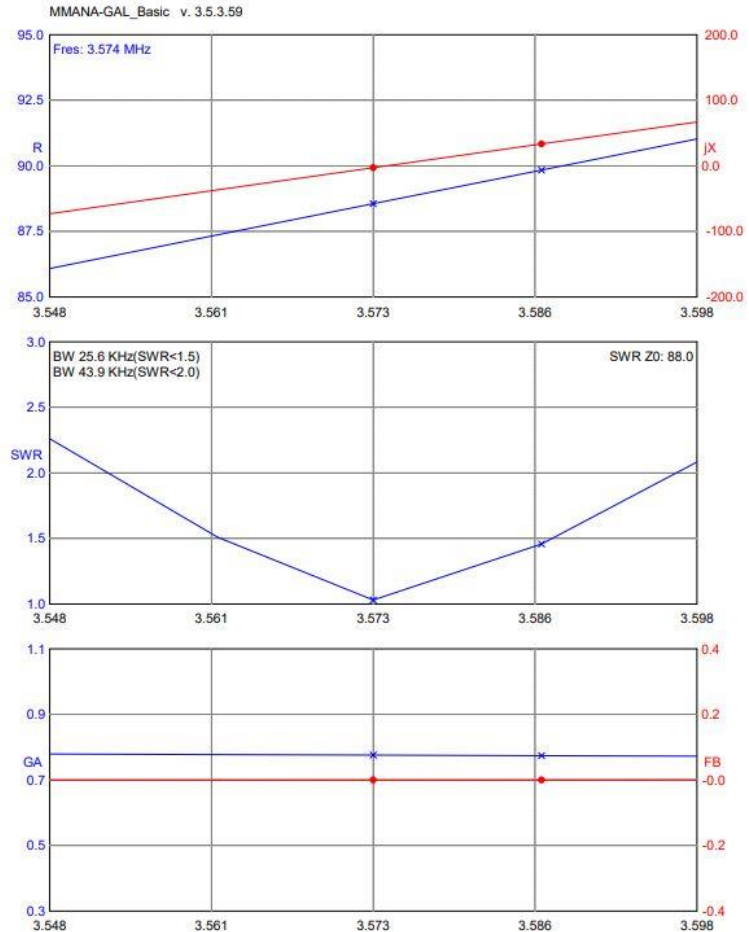

$L_{LOAD} \approx 55 \mu H$

# vFWLL MMANA AzEI Plot..

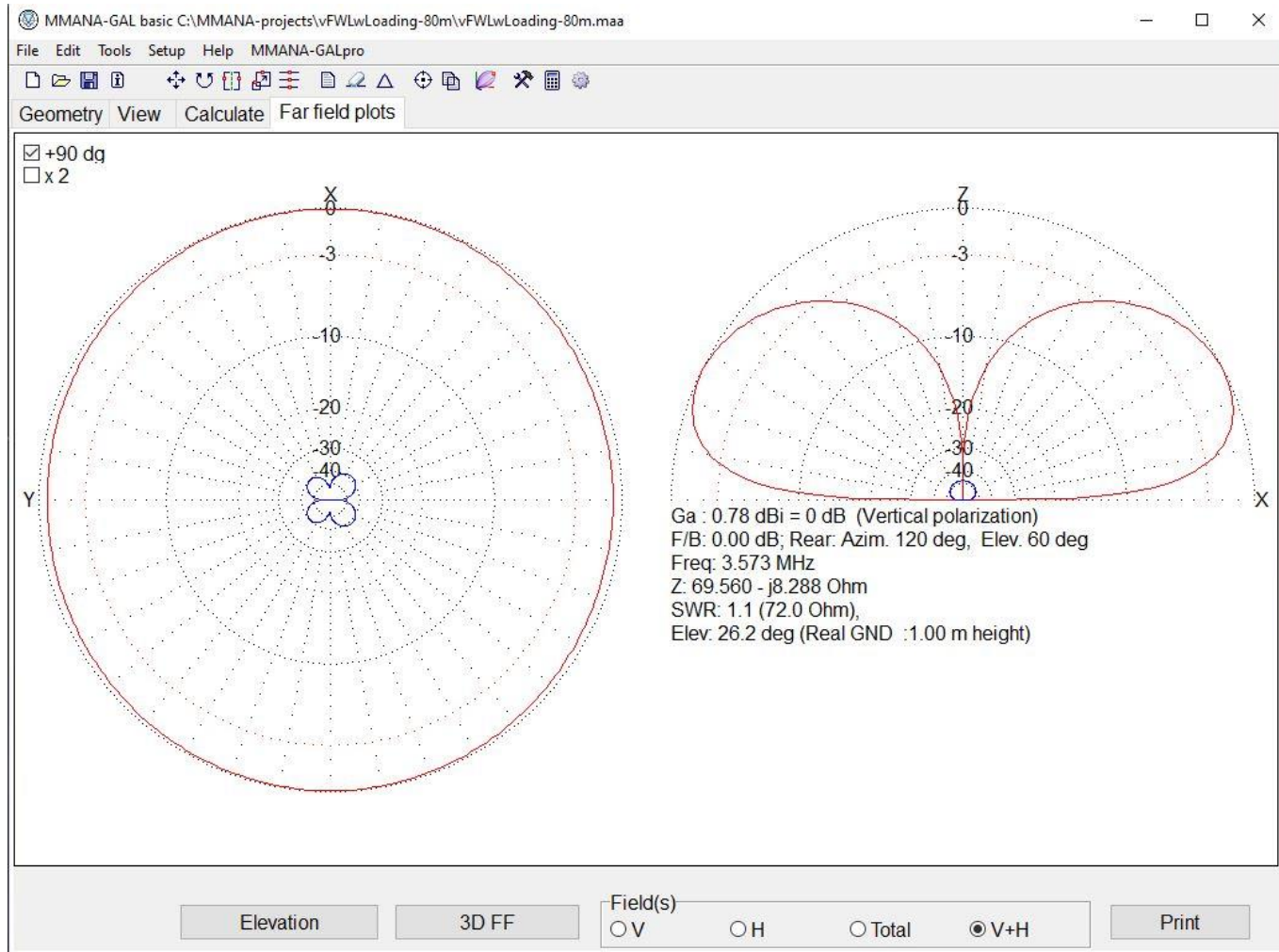

# vFWLL Far-Field..

This 80m/vFWLL is *not* a Cloud-Heater!!

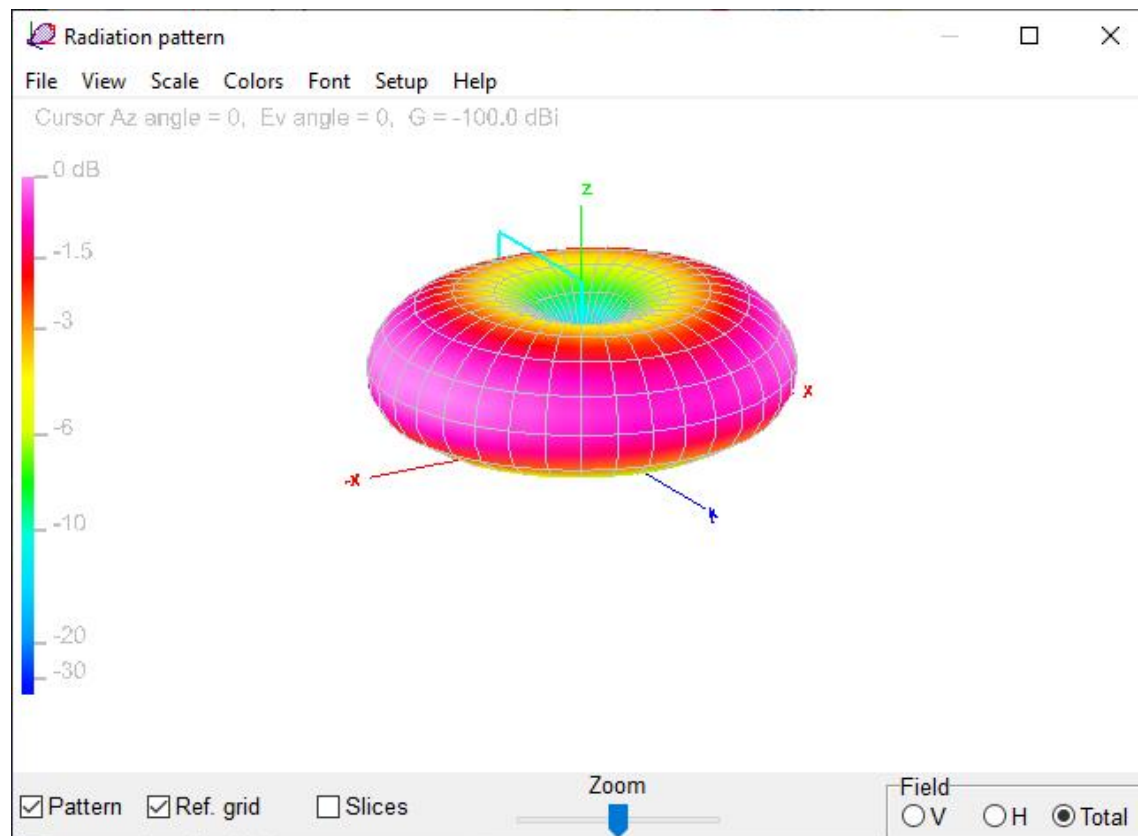

# Let's Explore..

## ■ Simulation Experiment:

- MMANA model with vertical/full-sized 80m EFHW as reference
- Compare vFWLL FF-response with; (i) EFHW/Inverted-L, (ii) vFWL (full-sized), (iii) vFWLL

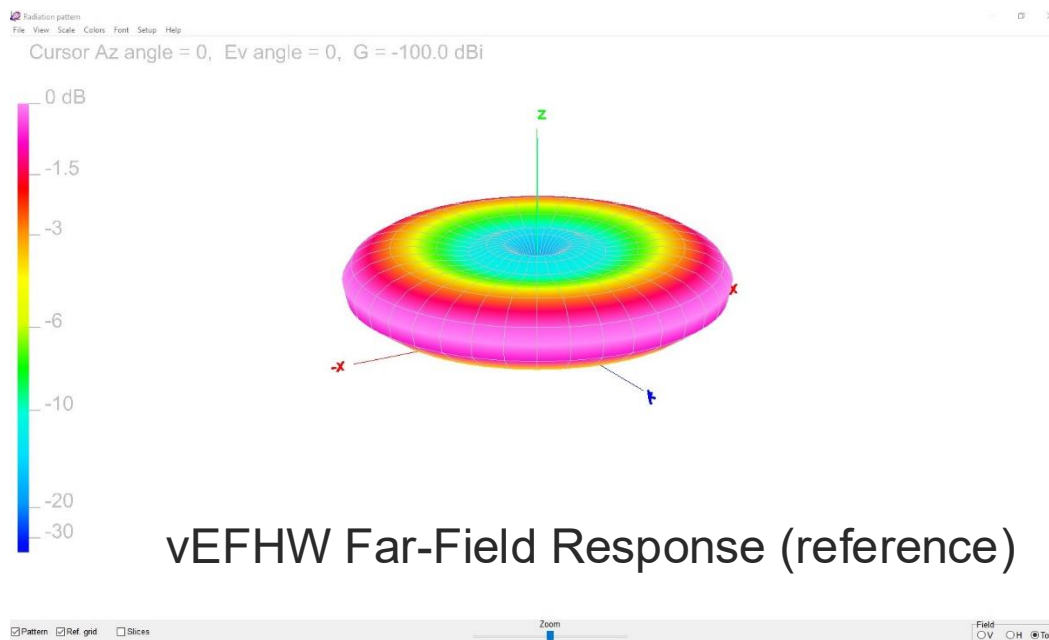

# Comparison: 'EFHW' vs. 'vEFHW'

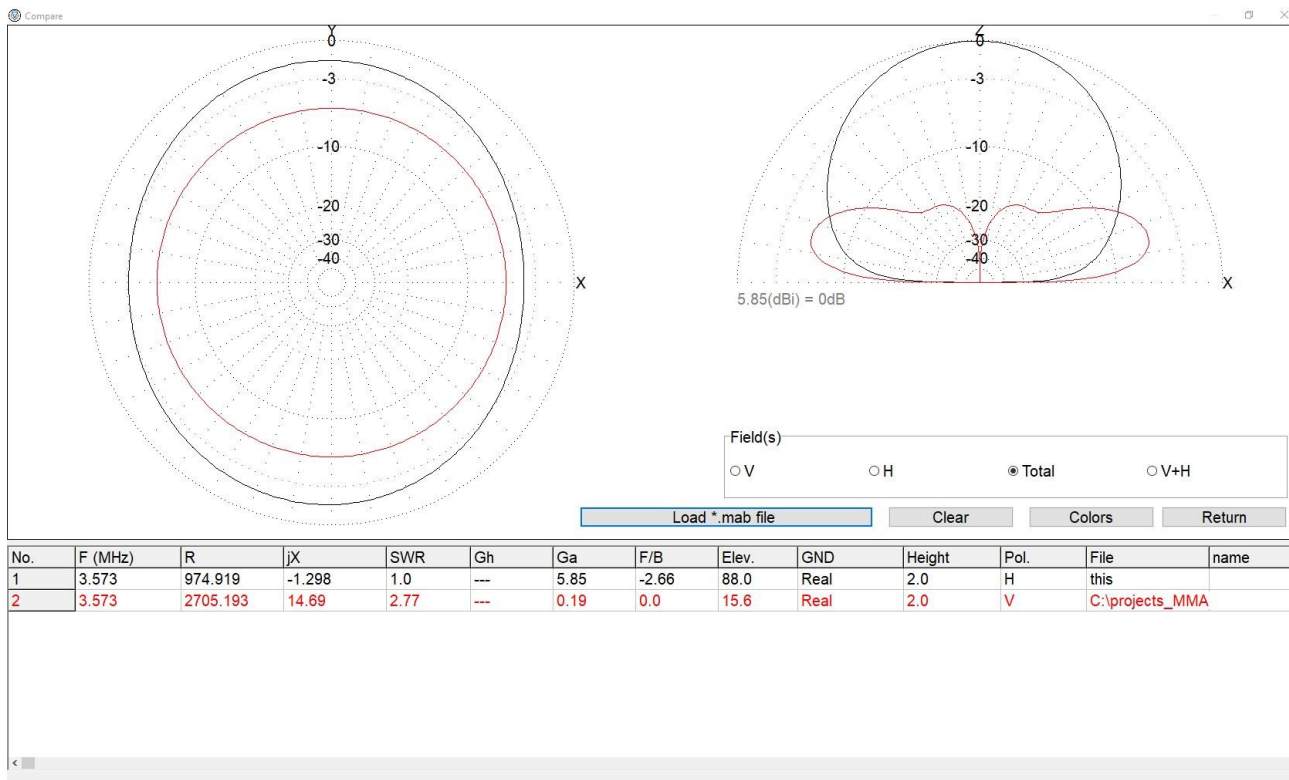

# Comparison: 'vFWLL' vs. 'vFWL'

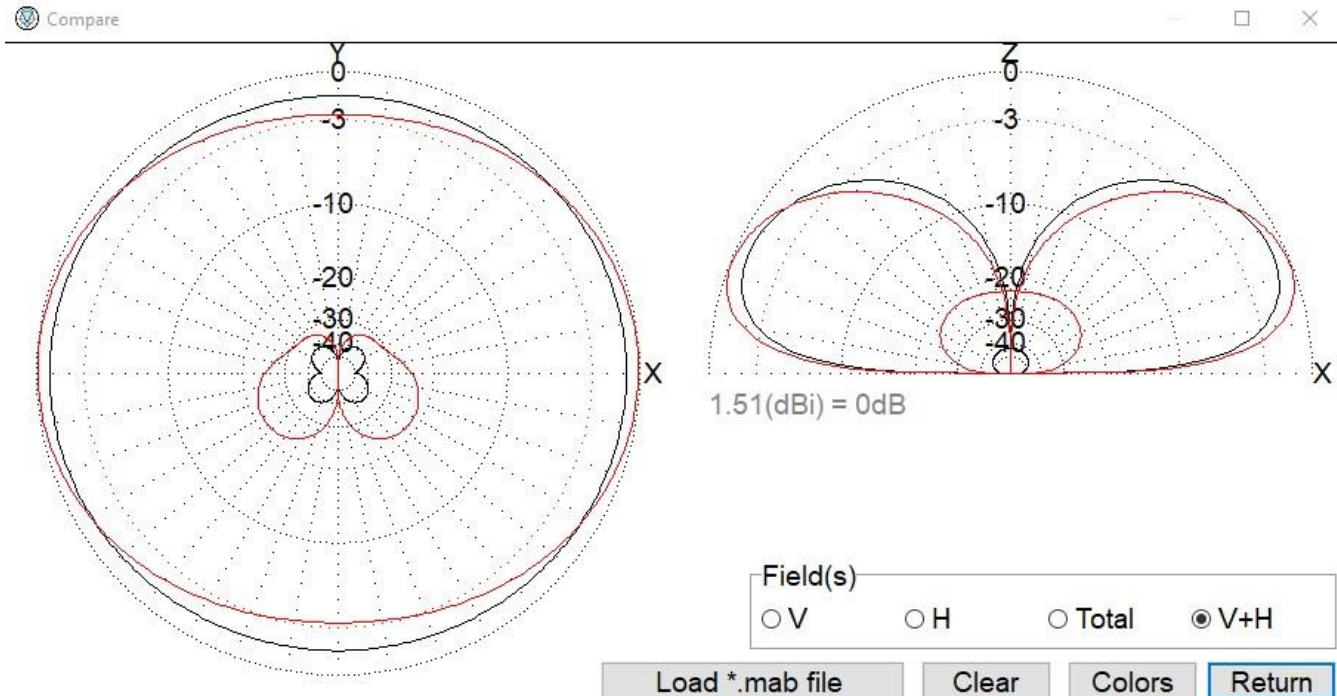

| No. | F (MHz) | R       | jX     | SWR  | Gh  | Ga   | F/B  | Elev. | GND  | Height | Pol. | File       | name |
|-----|---------|---------|--------|------|-----|------|------|-------|------|--------|------|------------|------|
| 1   | 3.573   | 88.559  | -2.68  | 1.03 | --- | 0.78 | -0.0 | 25.3  | Real | 2.0    | V    | this       |      |
| 2   | 3.573   | 206.566 | -0.816 | 2.35 | --- | 1.51 | -0.0 | 21.9  | Real | 2.0    | V    | C:\project |      |

# Comparison: 'vFWLL' vs. 'vEFHW'

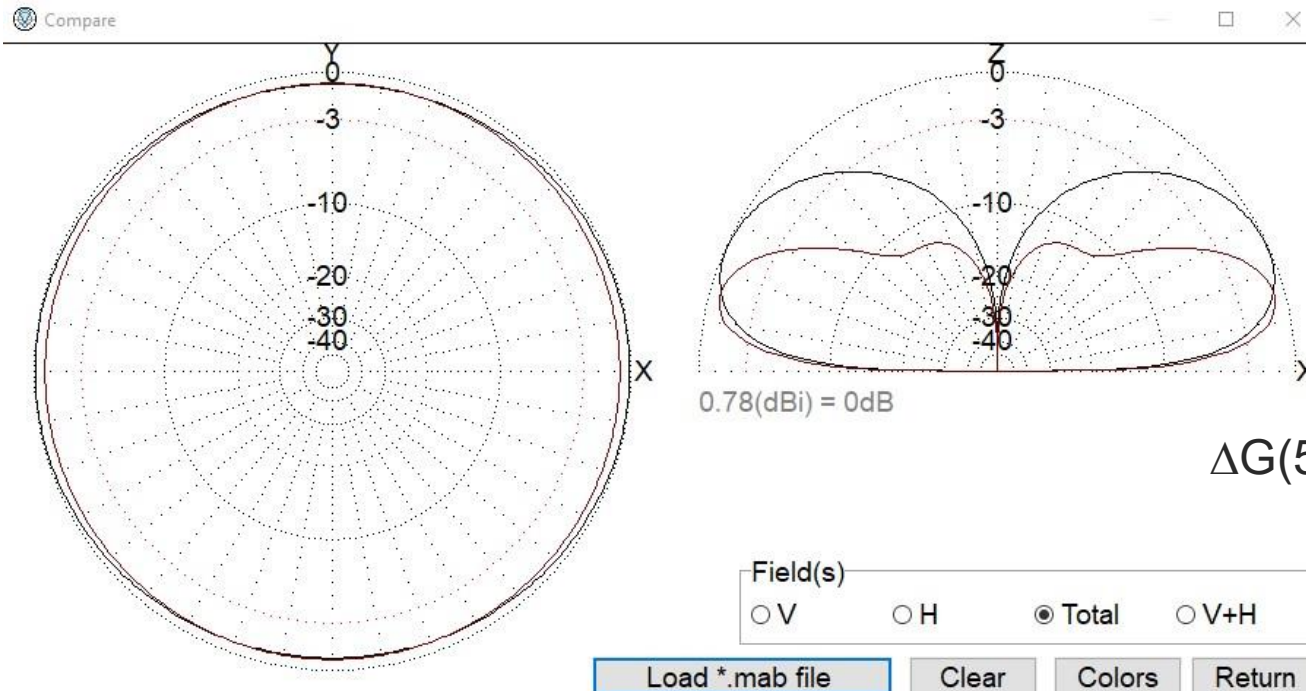

$\Delta G(5\text{degs}) < 1\text{dB!}$

| No. | F (MHz) | R       | jX    | SWR   | Gh  | Ga   | F/B  | Elev. | GND  | Height | Pol. | File       | name |
|-----|---------|---------|-------|-------|-----|------|------|-------|------|--------|------|------------|------|
| 1   | 3.573   | 88.559  | -2.68 | 1.03  | --- | 0.78 | -0.0 | 25.3  | Real | 2.0    | V    | this       |      |
| 2   | 3.573   | 2705.19 | 14.69 | 30.74 | --- | 0.19 | 0.0  | 15.6  | Real | 2.0    | V    | C:\project |      |

# Comparison: 'vFWLL' vs. 'vEFHW' (ref) vs. 'vFWL'..

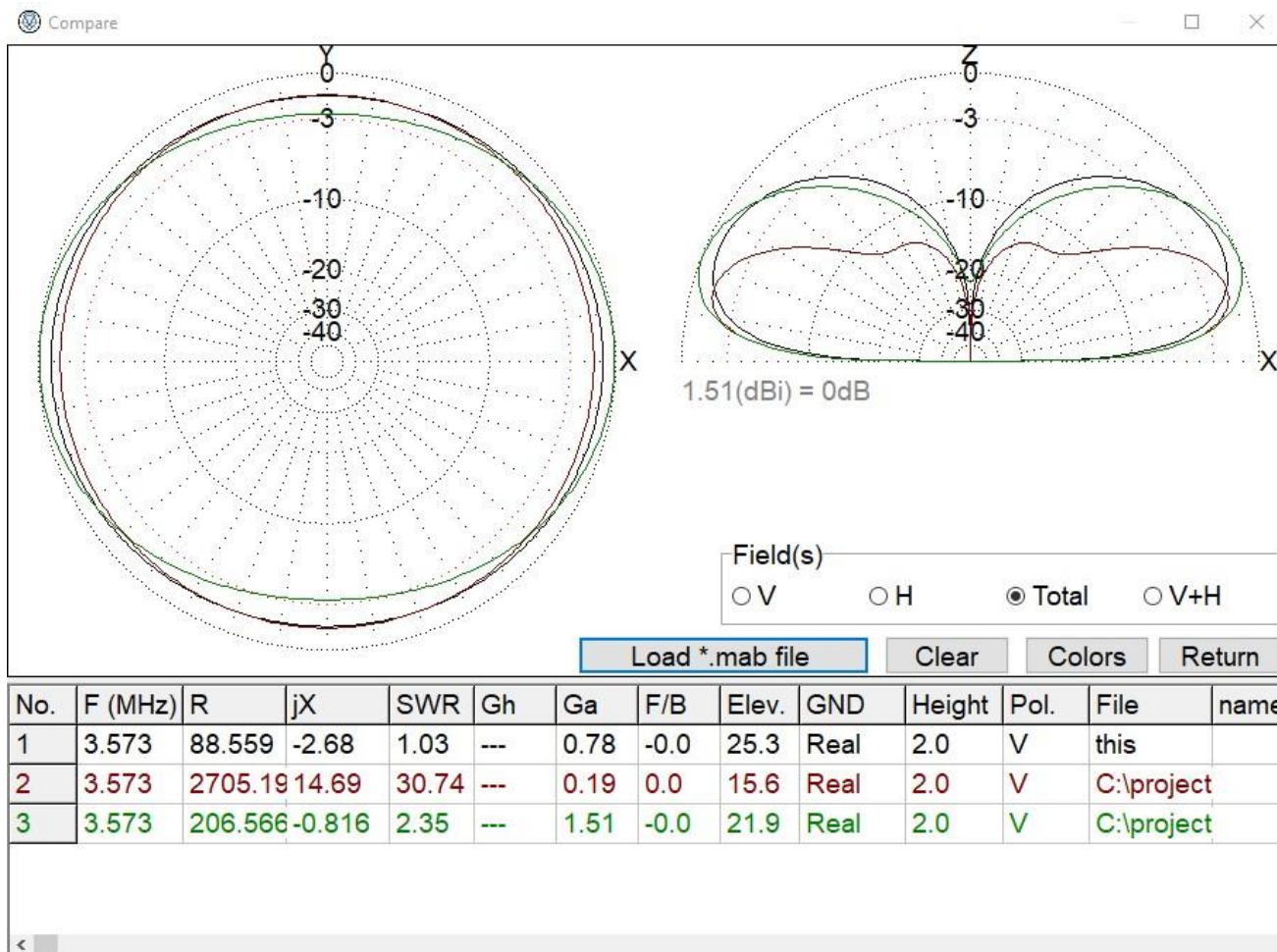

# What do we have?

- 80m full-wave loop in quarter-sized footprint
  - No NVIS!
  - Gain increase ( $\sim 0.5\text{dB}$ ) relative to vEFHW
  - Gain decrease ( $< 1\text{dB}$ ; 5degs TOA) relative to full-sized vFWL and vEFHW
- So.. Enough Theory/Simulation/Conjecture.. Let's Build Something!
  - Step-1: Model in MMANA (done!)
  - Step-2: Design/Fabricate loading-coils
  - Step-3: Kit
  - Step-4: Deploy and Test

# vFWLL Loading-Coil Design

- Use 3/4-inch PVC as coil former
- 16-gauge magnet-wire for winding(s)
  - Close-wind coils (wire is enameled)
- Use commonly available inductor design calculators for an initial number-of-turns estimate:
  - $N \cdot TPUL \approx \frac{L}{\pi R_{Coil}^2 \mu_0 \mu_R}$  ('TPUL'  $\equiv$  'Turns-per-Unit Length')
  - Verify inductance-value with impedance bridge

# Loading Coil Fabrication..



# vFWLL Kit..



# [ vFWLL Deployment.. ]



# vFWLL Deployment II (NanoVNA)..

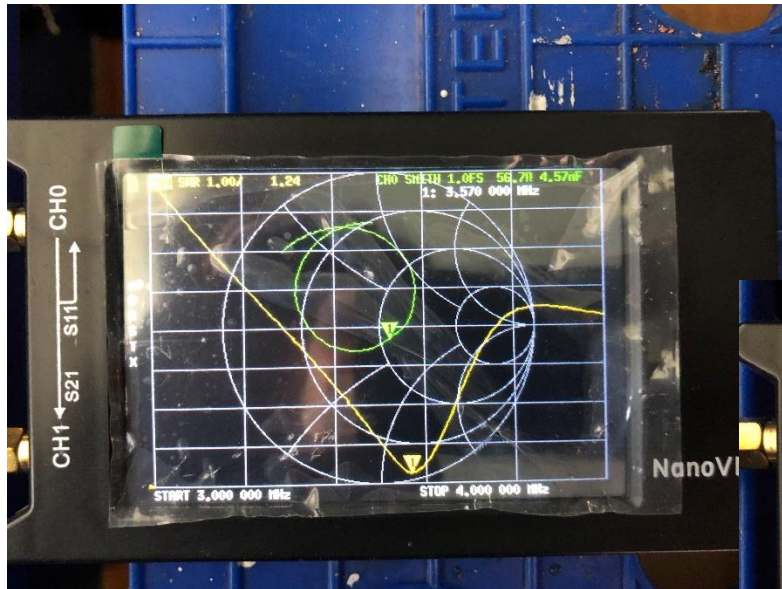

40KHz B/W (2:1 SWR)

Multiband Resonance

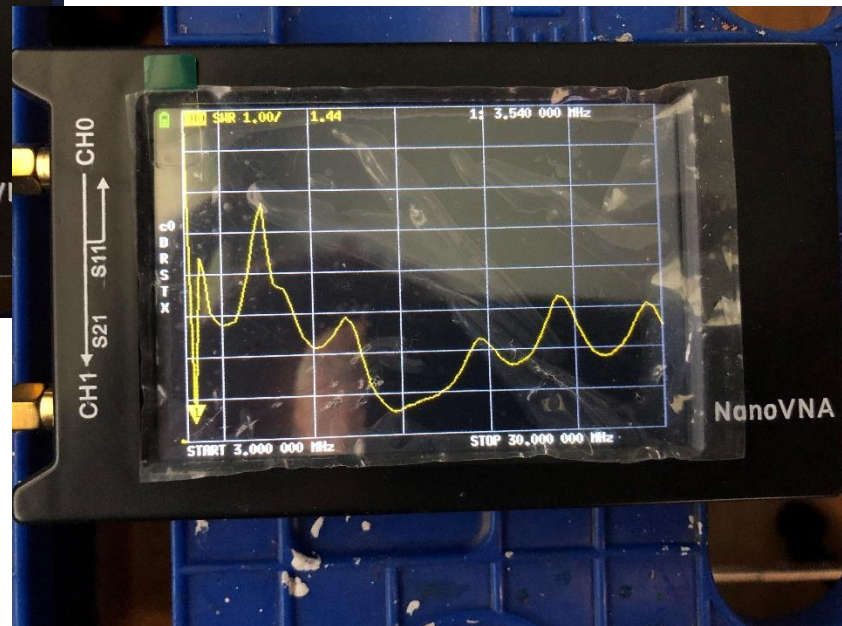



# Discussion..

- Disclaimer: I did not invent vFWLL, but I believe it to be undervalued as a DX-capable low-Band antenna structure
- Take-Aways
  - Quarter-sized form-factor (80m loop in 40m loop footprint)
  - 4x loading-coils (appx.  $55\mu\text{H} \approx 150\text{-turns}$  on 3/4-inch PVC form)
  - Balun required at feedpoint: 4:1 ( $Z_{\text{OUT}}/Z_{\text{IN}}$ ) No radials
  - Approximate omnidirectional response pattern ( $0.5\text{dB} \perp$  vFWLL plane)
  - DX-capable (within 1-dB of full-sized vFWL in far-field)
  - No cloud-heating ( $\sim$ NVIS)
  - Unipolar: V/H polarization depending upon feedpoint
  - Effective multiband response (1:1 SWR with clean-up tuner on 40m, 20M, 15m, and 10m)
  - Increased response in range of 20degs-50degs elevation relative to vEFHW. This is another possible advantage relative to vEFHW, (re: 'punch-through' 'D', 'E' ionosphere layers for access to ducting in 'F1-2' layers)
- Bottom-Line: I no longer need a 'balloon-hoisted' EFHW!!

[ But Wait.. ]

---

# There's MORE!!

We observe the vFWLL concept worked well on 80m

Q: Can vFWLL result be extended to 160m?

A: Yes!

# 160m/vFWLL..

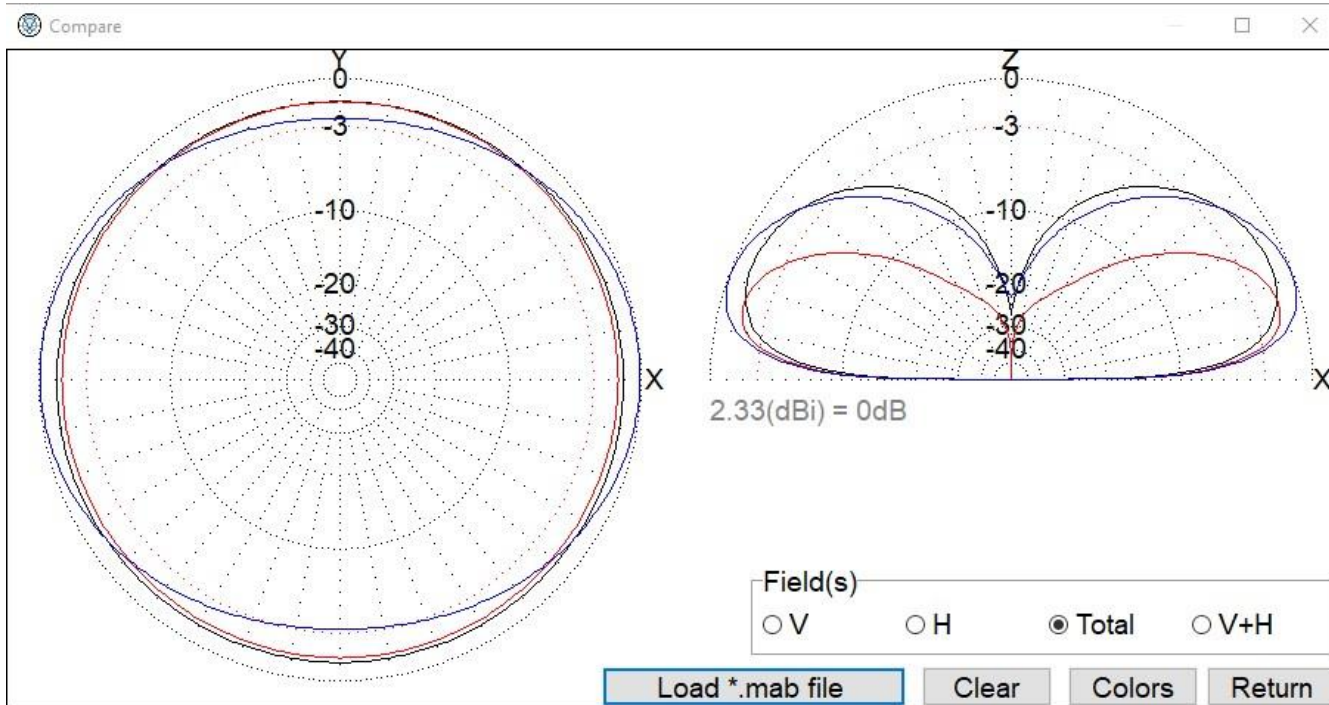

| No. | F (MHz) | R       | jX      | SWR   | Gh  | Ga   | F/B   | Elev. | GND  | Height | Pol. | File       | name |
|-----|---------|---------|---------|-------|-----|------|-------|-------|------|--------|------|------------|------|
| 1   | 1.84    | 28.638  | 2.733   | 1.75  | --- | 1.36 | -0.02 | 24.8  | Real | 2.0    | V    | this       |      |
| 2   | 1.84    | 4082.19 | 10.152  | 81.64 | --- | 1.01 | 0.0   | 15.7  | Real | 0.0    | V    | C:\project |      |
| 3   | 1.84    | 209.403 | -10.645 | 4.2   | --- | 2.33 | -0.01 | 20.8  | Real | 2.0    | V    | C:\project |      |

Imagine!



[ But Wait.. ]

---

# There's (EVEN) MORE!!

O: vFWLL is approximately omnidirectional

Q: Can vFWLL be used as building-block for phased array?

A: Yes!

# 2x80m/vFWLL Phased Array (180degs)..

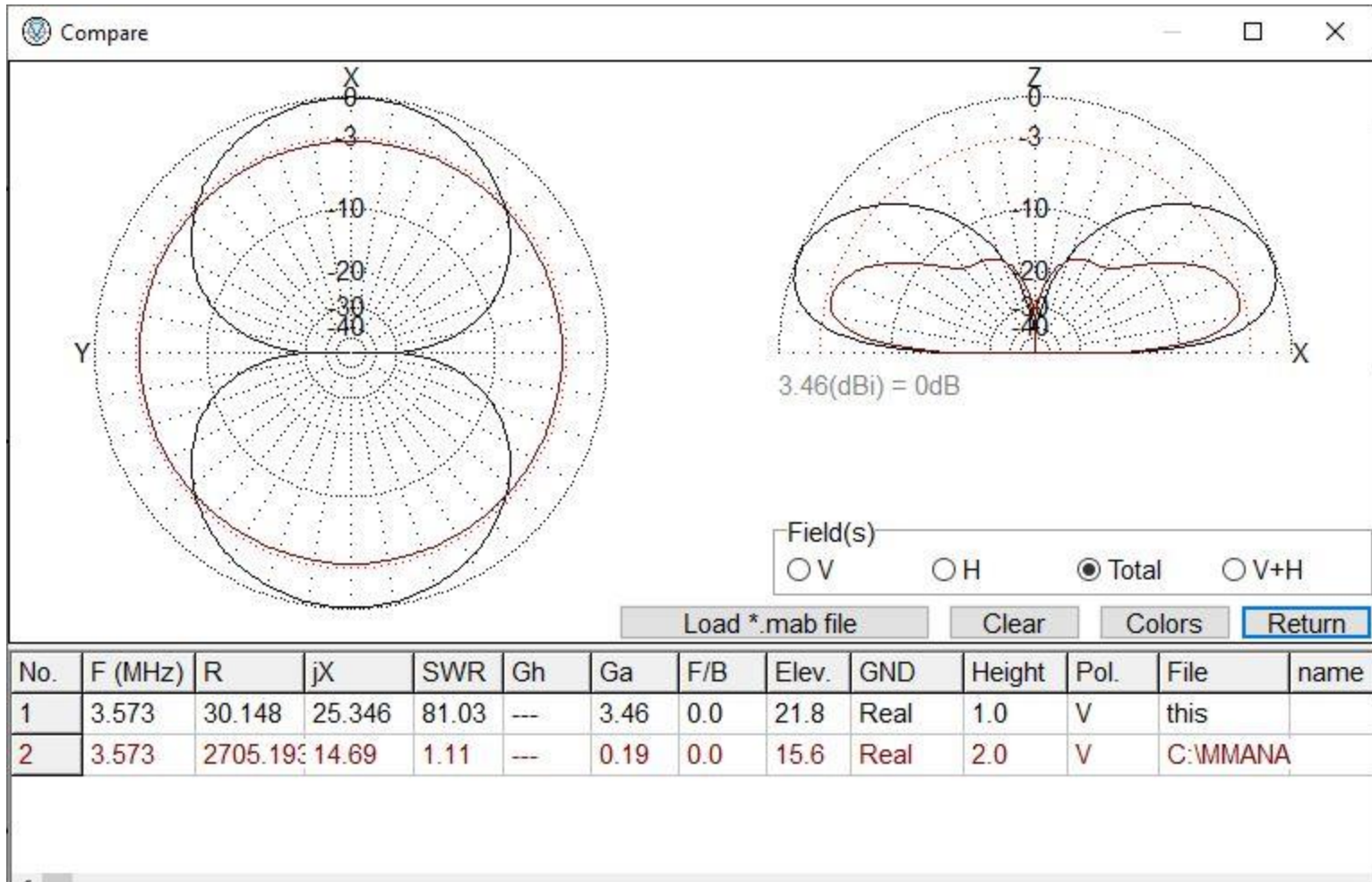

# 2x80m/vFWLL Phased Array (90degs)..

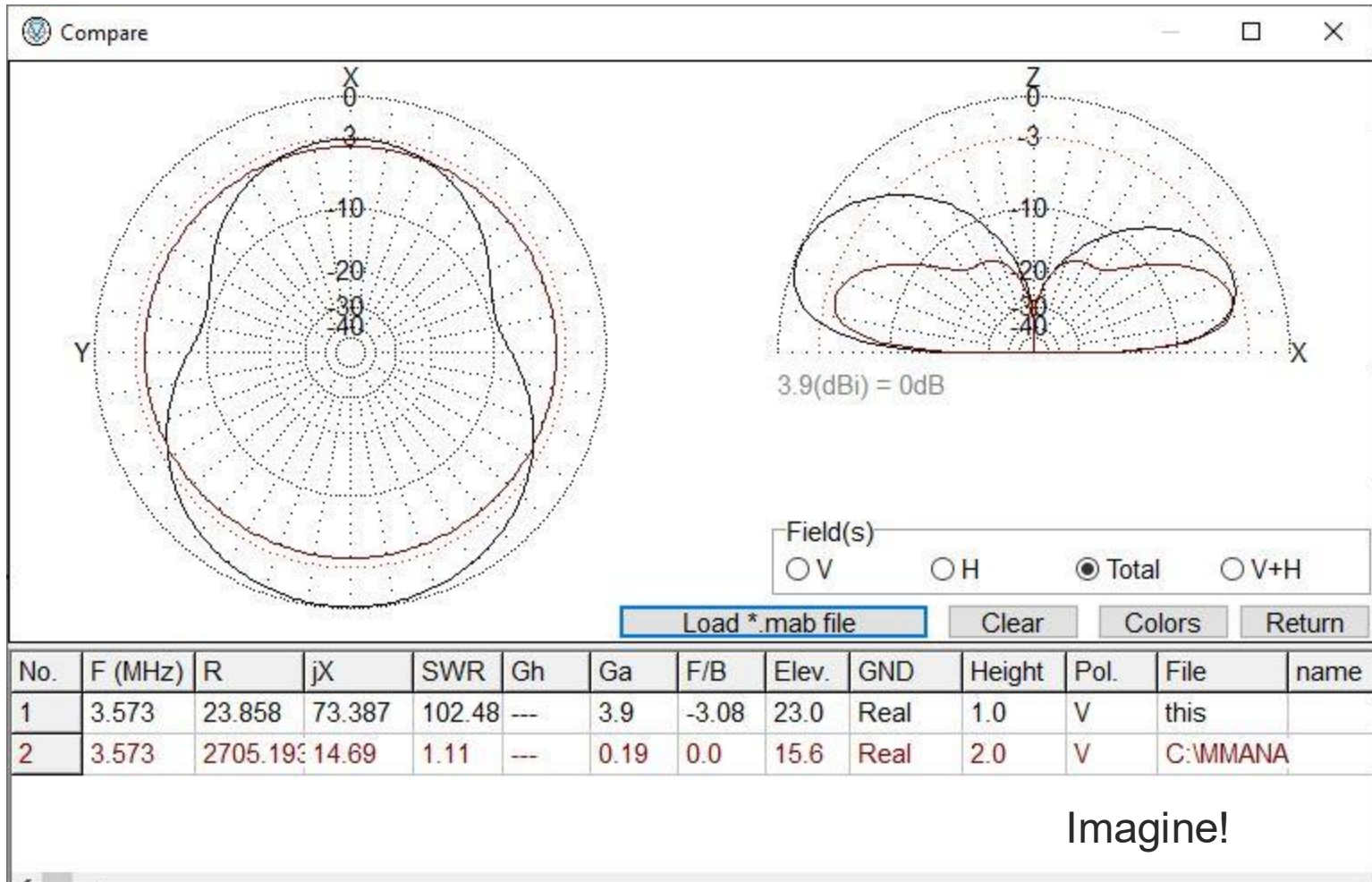

[ But Wait.. ]

---

# WHY?!

Q: Why does the vFWLL work so well?

A: It all comes down to ground reflections..

# Impact of Ground-Reflections upon vFWLL Performance

- Recall ground-reflection inverts incident EM field
  - Destructive combination of wavefronts in far-field reduces ToA gain
- vFWL and vFWLL strongly attenuates  $E_H$ 
  - Recall  $E_H$  interacts most strongly with ground-sheet:
    - (i) absorption and (ii) reflection
  - This is the source of vFWL/vFWLL 'ground-independence'
    - Only when vertically polarized!!
  - Observe similarity to  $\lambda/4$  vertical (w/counterpoise) which leverages GR as means to cancel  $E_H$
- vFWL/vFWLL Attenuate GR: Attenuated GR  $\rightarrow$  Low ToA!
  - $E_H$  cancellation is prior to GR  $\rightarrow$  Minimal ground-sheet interaction  $\rightarrow$  Minimal ToA gain reduction!!

# The Bottom-Line..

- We now have available a reduced-footprint, high-performance alternative for 80m
  - Reconsider EFHW/Dipole/Inverted-L deployment versus vFWLL
  - 'Balloon-Hoisted', What?! [It's Not As Good!!!]
- Consider 80m/vFWLL as building-block for more complex antennas
  - 4-square/octagon/n-gon phased-array – No radials!
- 80m/vFWLL form is extensible to 160m/vFWLL!!
  - MMANA model tells us 160m/vFWLL with 40m footprint will work well
  - Rework assuming 60m square footprint?
- Testimonial: Bill/KC0INQ has deployed and is currently using my original 80m/vFWLL to great advantage!
  
- What can you do with this? As the great John Lennon once said.. 'Imagine!'

# References..

- **ARRL Antenna Book** (Chapter-5) 2019 ISBN 978-1-62595-115-1 (Volume-1)
- W.L. Stutzman, G.A. Theile '**Antenna Theory and Design**' J. Wiley and Sons 1981 ISBN 0-471-04458-X
- W.D. Rawle '*The Method of Moments: A numerical Technique for Wire Antenna Design*', High Frequency Electronics Feb. 2006
- Callum McCormick/M0MCX '*Antenna Modeling for Complete Beginners - Model your own Dipole, Vertical, or Loop – MMANA NEC*', YouTube: <https://www.youtube.com/watch?v=15qdzgYe24E>

[ Much Appreciation! ]

---

- Thanks for Listening!!

- J.B. Anderson, PhD – *K8OS Radio Science*